

Ultrasonic Level Transmitter Model: ZJX-PA-M-A7



PRODUCT FEATURES AND APPLICATION FIELDS

Description:

The ZJX-PA-M-A7 ultrasonic liquid level transmitter uses the time required to emit ultrasonic waves through the material level or liquid level, reflect them, and calculate the distance. It does not come into contact with the medium, and has the characteristics of easy installation and maintenance, hygiene, and cleanliness. It is widely used for measuring the height of liquid and solid materials.

Features:

Concentrated energy with a 7.5 ° wave angle and strong anti-interference ability
Integrated design, repeatability<0.1%
Can set the level/distance measurement range, with an output accuracy of 0.2% F.S
With data remote transmission function and contact output
Multiple installation interfaces and anti-corrosion materials available for selection

Advantages:

0.3 meter blind spot with accurate measurement accuracy
Display resolution of 1mm with temperature display
Backlit display with filtering algorithm, capable of switching between Chinese and English
Support OEM/ODM customization

Application:

Petroleum and chemical industry
Smelting and building materials
Environmental protection, biopharmaceutical
Food, Beverage, Brewing
Civil engineering, engineering machinery
Power, mining, robot automation control
Monitoring of farmland and dams

PRODUCT PARAMETERS

Structure Type	Integrated Type, Separate Type
Measuring Range	0~60m
Output Signal	4-20mA (four wire system), 4-20mA (two wire system), Customizable
Power Supply	24VDC,220VAC
Resolution Ratio	3mm or 0.1% (whichever is greater)
Accuracy	0.3%~1.0%
Working Temp	Display Instrument: -20~+60°C, Probe: -20~+80°C
IP Rating	Display Instrument: IP66, Probe: IP68
Installation Method	Thread, Flange
Communication	RS485, RS232
Shell Material	Engineering Plastic,316SS

OVERALL DIMENSIONS

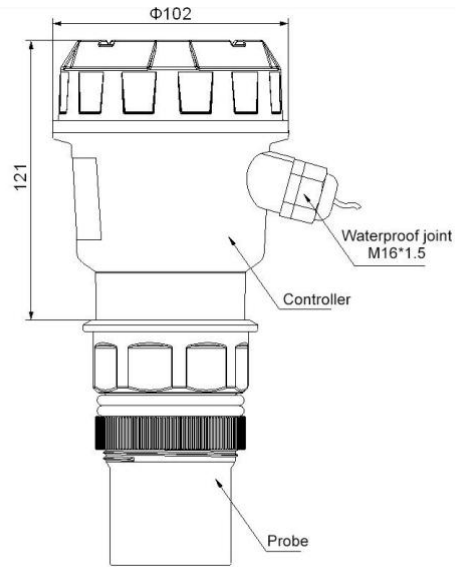

M60×2 or G2 Thread Sensor

PRODUCT CONNECTION MODE

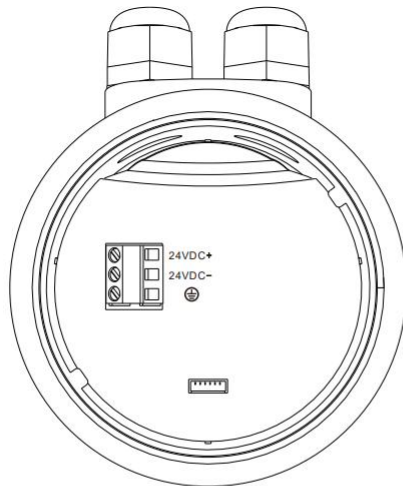

1	X	24VDC+	} 24VDC
2	X	24VDC-	
3	X	⊕	— GND

PRODUCT SELECTION TABLE

Code								
ZJX-PA-M-A7	Ultrasonic Level Transmitter							
	Code	Measuring Range						
	Fill In The	0 ~ 60m						
		Code	Structure Type					
		I	Integrated Type					
		S	Separate Type					
			Code	Output Signal				
			O1	4-20mA (four wire system)				
			O2	4-20mA (two wire system)				
			O3	Customizable				
			Code	Power Supply				
			P1	24VDC				
			P2	220VAC				
			Code	Installation Method				
			T	Thread				
			F	Flange				
				Code	Communication			
				C1	RS485			
				C2	RS232			
				Code	Shell Material			
				P	Engineering Plastic			
				S	316SS			
ZJX-PA-M-A7	5m	I	O1	P2	T	C1	P	Model No.Example

ZIJUXING

HUNAN ZIJUXING TECHNOLOGY CO., LTD.

Tel: +86-731-85473669

Fax: +86-731-85473669

E-mail: postmaster@zjxsensor.com web: www.zjxsensor.com

 Address: No. 319, Linyu Road, High tech Development Zone,
 Changsha City, Hunan Province, China