

## Exquisite Temperature Transmitter Model: ZJX-PA-PT-A1L2



### PRODUCT FEATURES AND APPLICATION FIELDS

#### Description:

The ZJX-PA-PT-A1L2 exquisite temperature transmitter is composed of a temperature sensor, compensation circuit, and conversion circuit. The internal resistance value changes with temperature, and the internal circuit converts its value into a linear analog output. The external structure is compact, making it convenient for on-site installation with space requirements.

#### Features:

- Multiple output signals can be selected
- Multiple installation interfaces can be selected
- Multiple anti-corrosion materials can be selected for temperature measurement positions
- Strong anti-interference, vibration resistance, and high mechanical strength
- The depth and diameter of measuring tube components can be selected

#### Advantages:

- Large measurement range (-200 °C -2000 °C)
- Compact structure for easy installation
- Fast response time and high measurement accuracy
- Support OEM/ODM customization

#### Application:

- Food and Beverage
- Oil, natural gas, chemical industry
- Measurement of environmental wastewater and exhaust gas
- Metallurgy and glass industry
- Steel, building materials
- Hydraulic and engineering machinery
- Plastic and chemical fiber textile machinery
- Glue measurement and paint spraying equipment
- New energy, semiconductors

## PRODUCT PARAMETERS

Measuring Range	-200℃~2000℃
Display Type	Do not display, Local display
Structure Type	Compact, Explosion-proof
Output/Communication	4-20mA,4-20mA+Hart,0-10V,1-5V,Customizable
Power Supply	12-32V
Process Connector	G1/4, G1/2,1.5",DN25,Customizable
Insert Tube Diameter	6mm ,8mm ,12mm ,Customizable
Insert Tube Length	25mm, 50mm,300mm,1000mm,Customizable
Insert Tube Material	304SS,316LSS,PTFE,Customizable
Accuracy	±0.5%FS
Electrical Connections	M12*1 connection, Hirschmann,1/2NPT(Explosion proof enclosure)
Protection Grade	IP65,IP67

## OVERALL DIMENSIONS

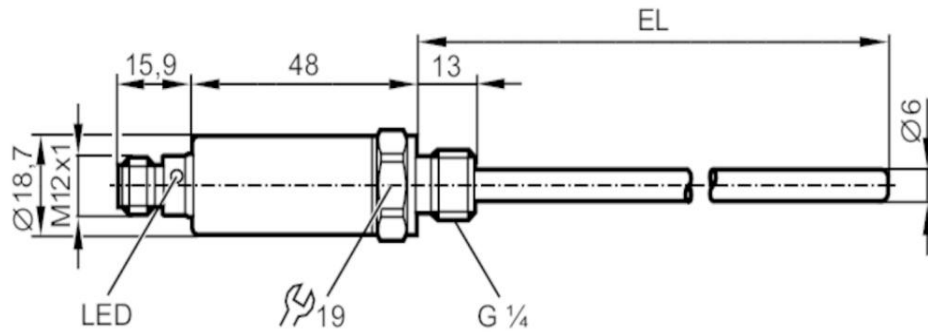

## PRODUCT CONNECTION MODE

### Circular connector M12 x 1 (4-pin)

		2-wire	3-wire
	$U_B$	1	1
	0V	3	3
	S+	-	4

# PRODUCT SELECTION TABLE

Code	Exquisite Temperature Transmitter									
ZJX-PA-PT-A1L2	Exquisite Temperature Transmitter									
	Code	Pressure Range								
	Fill In The Actual Demand	-200°C~2000°C								
	Code	Display Type								
	N	Do not display								
	D	Local display								
	Code	Structure Type								
	C	Compact								
	E	Explosion-proof								
	Code	Output/Communication								
	O1	4-20mA								
	O2	4-20mA+Hart								
	O3	0-10V								
	O4	1-5V								
	O5	Customizable								
	Code	Process Connector								
	P1	G1/4								
	P2	G1/2								
	P3	1.5"								
	P4	DN25								
	P5	Customizable								
	Code	Insert Tube Diameter								
	D1	6mm								
	D2	8mm								
	D3	12mm								
	D4	Customizable								
	Code	Insert Tube Length								
	L1	25mm								
	L2	50mm								
	L3	300mm								
	L4	1000mm								
	L5	Customizable								
	Code	Insert Tube Material								
	T1	304SS								
	T2	316LSS								
	T3	PTFE								
	T4	Customizable								
	Code	Electrical Connections								
	M	M12*1 connection								
	H	Hirschmann								
	E	1/2NPT(Explosion proof enclosure)								
ZJX-PA-PT-A1L2	0-200°C	D	C	O2	P1	D1	L2	T1	M	Model No.Example

**ZIJUXING**

HUNAN ZIJUXING TECHNOLOGY CO., LTD.

Tel: +86-731-85473669

Fax: +86-731-85473669

E-mail:postmaster@zjxsensor.com web:www.zjxsensor.com

 Address:No. 319, Linyu Road, High tech Development Zone,  
Changsha City, Hunan Province, China